

FUJIF **ArtiqAir**

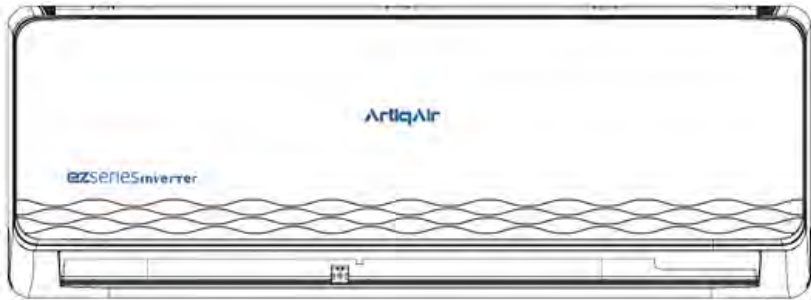

ezseries inverter

Lebih Mudah, Lebih Nyaman

Installation and Operation Manual for your Wall-Mounted Air Conditioner

This manual is for Wall-Mounted Air Conditioner

Refrigerant R32 -----	5-10
Safety Precautions -----	11-12
Name and Function of each Part -----	13
Display icon -----	14
Use of Remote Controller -----	15-17
Cleaning and Maintenance -----	18
Notice for installation -----	19
Installation Instruction -----	20-22
Fault Analysis -----	23

Thank you for choosing our air conditioner!

Before using the product, please carefully read this manual and keep it in safe for later reference. Please ask for professionals to install the product.

NOTE:

1. This appliance is not intended for use by persons (including children) with reduced physical, sensory or mental capabilities, or lack of experience and knowledge, unless they have been given supervision or instruction concerning use of the appliance by a person responsible for their safety. Children should be supervised to ensure that they do not play with the appliance.
2. If the supply cord is damaged, it must be replaced by the manufacturer, its service agent or similarly qualified persons in order to avoid a hazard.
3. The appliance shall be installed in accordance with national wiring regulations.
4. How to fixed the appliance to its support please refer to detail information of installation.

Refrigerant R32

■ Introduction to refrigerant R32

Refrigerant R32 is environmentally friendly, combustible and odorless. R32 can burn and explode under certain conditions. However, there will be no risk of burning and explosion if you comply with the following table to install your air conditioner in a room with an appropriate area and follow the safety precautions.

■ Room area for air conditioner with refrigerant R32

Refrigerants	Capacity (Btu)	Room Area
R32	9K	Above 10 m ²
	12K	Above 13 m ²
	18K	Above 15 m ²
	22K/24K	Above 25 m ²

Refrigerant R32

■ Warnings (use of refrigerant R32)

- Do not use means to accelerate the defrosting process or to clean, other than those recommended by the manufacturer.
- The appliance shall be stored in a room without continuously operating ignition sources (for example: open flames, an operating gas appliance or an operating electric heater).
- Do not pierce or burn.
- Be aware that the refrigerants may not contain an odour.
- Appliance 12K should be installed, operated and stored in a room with a floor area larger than 11 m².
- Appliance 9K should be installed, operated and stored in a room with a floor area larger than 10 m².
- Compliance with national gas regulations shall be observed.
- Keep ventilation openings clear of obstruction.
- The appliance shall be stored so as to prevent mechanical damage from occurring.
- A warning that the appliance shall be stored in a well-ventilated area where the room size corresponds to the room area as specified for operation.
- Any person who is involved with working on or breaking into a refrigerant circuit should hold a current valid certificate from an industry-accredited assessment authority, which authorises their competence to handle refrigerants safely in accordance with an industry recognised assessment specification.
- Servicing shall only be performed as recommended by the equipment manufacturer. Maintenance and repair requiring the assistance of other skilled personnel shall be carried out under the supervision of the person competent in the use of flammable refrigerants.





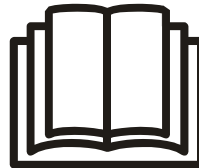

Caution: Risk of fire/
flammable materials
(Required for R32/R290
units only)



IMPORTANT NOTE: Read this manual carefully before installing or operating your new air conditioning unit. Make sure to save this manual for future reference.

Explanation of symbols displayed on the unit (For R32 only):

	WARNING	This symbol shows that this appliance used a flammable refrigerant. If the refrigerant is leaked and exposed to an external ignition source, there is a risk of fire.
	CAUTION	This symbol shows that the operation manual should be read carefully.
	CAUTION	This symbol shows that a service personnel should be handling this equipment with reference to the installation manual.
	CAUTION	This symbol shows that information is available such as the operating manual or installation manual.

Refrigerant R32

■ Warnings (use of refrigerant R32)

1. Transport of equipment containing flammable refrigerants See transport regulations.
2. Marking of equipment using signs See local regulations.
3. Disposal of equipment using flammable refrigerants See national regulations.
4. Storage of equipment/appliances

The storage of equipment should be in accordance with the manufacturer's instructions.

5. Storage of packed (unsold) equipment

Storage package protection should be constructed such that mechanical damage to the equipment inside the package will not cause a leak of the refrigerant charge. The maximum number of pieces of equipment permitted to be stored together will be determined by local regulations.

6. Information on servicing

- 1) Checks to the area

Prior to beginning work on systems containing flammable refrigerants, safety checks are necessary to ensure that the risk of ignition is minimised. For repair to the refrigerating system, the following precautions shall be complied with prior to conducting work on the system.

- 2) Work procedure

Work shall be undertaken under a controlled procedure so as to minimise the risk of a flammable gas or vapour being present while the work is being performed.

- 3) General work area

All maintenance staff and others working in the local area shall be instructed on the nature of work being carried out. Work in confined spaces shall be avoided. The area around the workspace shall be sectioned off. Ensure that the conditions within the area have been made safe by control of flammable material.

- 4) Checking for presence of refrigerant

The area shall be checked with an appropriate refrigerant detector prior to and during work, to ensure the technician is aware of potentially flammable atmospheres. Ensure that the leak detection equipment being used is suitable for use with flammable refrigerants, i.e. non-sparking, adequately sealed or intrinsically safe.

- 5) Presence of fire extinguisher

If any hot work is to be conducted on the refrigeration equipment or any associated parts, appropriate fire extinguishing equipment shall be available to hand. Have a dry powder or CO2 fire extinguisher adjacent to the charging area.

- 6) No ignition sources

No person carrying out work in relation to a refrigeration system which involves exposing any pipe work that contains or has contained flammable refrigerant shall use any sources of ignition in such a manner that it may lead to the risk of fire or explosion. All possible ignition sources, including cigarette smoking, should be kept sufficiently far away from the site of installation, repairing, removing and disposal, during which flammable refrigerant can possibly be released to the surrounding space. Prior to work taking place, the area around the equipment is to be surveyed to make sure that there are no flammable hazards or ignition risks. No Smoking signs shall be displayed.

- 7) Ventilated area

Ensure that the area is in the open or that it is adequately ventilated before breaking into the system or conducting any hot work. A degree of ventilation shall continue during the period that the work is carried out. The ventilation should safely disperse any released refrigerant and preferably expel it externally into the atmosphere.

- 8) Checks to the refrigeration equipment

Where electrical components are being changed, they shall be fit for the purpose and to the correct specification. At all times the manufacturer's maintenance and service guidelines shall be followed. If in doubt consult the manufacturer's technical department for assistance. The following checks shall be applied to installations using flammable refrigerants:

The charge size is in accordance with the room size within which the refrigerant containing parts are installed;

The ventilation machinery and outlets are operating adequately and are not obstructed;

Refrigerant R32

■ Warnings (use of refrigerant R32)

If an indirect refrigerating circuit is being used, the secondary circuit shall be checked for the presence of refrigerant; Marking to the equipment continues to be visible and legible. Markings and signs that are illegible shall be corrected;

Refrigeration pipe or components are installed in a position where they are unlikely to be exposed to any substance which may corrode refrigerant containing components, unless the components are constructed of materials which are inherently resistant to being corroded or are suitably protected against being so corroded.

9) Checks to electrical devices

Repair and maintenance to electrical components shall include initial safety checks and component inspection procedures. If a fault exists that could compromise safety, then no electrical supply shall be connected to the circuit until it is satisfactorily dealt with. If the fault cannot be corrected immediately but it is necessary to continue operation, an adequate temporary solution shall be used. This shall be reported to the owner of the equipment so all parties are advised.

Initial safety checks shall include:

That capacitors are discharged: this shall be done in a safe manner to avoid possibility of sparking;

That there no live electrical components and wiring are exposed while charging, recovering or purging the system;

That there is continuity of earth bonding.

7. Repairs to sealed components

1) During repairs to sealed components, all electrical supplies shall be disconnected from the equipment being worked upon prior to any removal of sealed covers, etc. If it is absolutely necessary to have an electrical supply to equipment during servicing, then a permanently operating form of leak detection shall be located at the most critical point to warn of a potentially hazardous situation.

2) Particular attention shall be paid to the following to ensure that by working on electrical components, the casing is not altered in such a way that the level of protection is affected. This shall include damage to cables, excessive number of connections, terminals not made to original specification, damage to seals, incorrect fitting of glands, etc.

Ensure that apparatus is mounted securely.

Ensure that seals or sealing materials have not degraded such that they no longer serve the purpose of preventing the ingress of flammable atmospheres. Replacement parts shall be in accordance with the manufacturer's specifications.

NOTE: The use of silicon sealant may inhibit the effectiveness of some types of leak detection equipment. Intrinsically safe components do not have to be isolated prior to working on them.

8. Repair to intrinsically safe components

Do not apply any permanent inductive or capacitance loads to the circuit without ensuring that this will not exceed the permissible voltage and current permitted for the equipment in use. Intrinsically safe components are the only types that can be worked on while live in the presence of a flammable atmosphere. The test apparatus shall be at the correct rating. Replace components only with parts specified by the manufacturer. Other parts may result in the ignition of refrigerant in the atmosphere from a leak.

9. Cabling

Check that cabling will not be subject to wear, corrosion, excessive pressure, vibration, sharp edges or any other adverse environmental effects. The check shall also take into account the effects of aging or continual vibration from sources such as compressors or fans.

10. Detection of flammable refrigerants

Under no circumstances shall potential sources of ignition be used in the searching for or detection of refrigerant leaks. A halide torch (or any other detector using a naked flame) shall not be used.

11. Leak detection methods

The following leak detection methods are deemed acceptable for systems containing

Refrigerant R32

■ Warnings (use of refrigerant R32)

flammable refrigerants. Electronic leak detectors shall be used to detect flammable refrigerants, but the sensitivity may not be adequate, or may need re-calibration. (Detection equipment shall be calibrated in a refrigerant-free area.) Ensure that the detector is not a potential source of ignition and is suitable for the refrigerant used. Leak detection equipment shall be set at a percentage of the LFL of the refrigerant and shall be calibrated to the refrigerant employed and the appropriate percentage of gas (25 % maximum) is confirmed. Leak detection fluids are suitable for use with most refrigerants but the use of detergents containing chlorine shall be avoided as the chlorine may react with the refrigerant and corrode the copper pipe-work. If a leak is suspected, all naked flames shall be removed/ extinguished. If a leakage of refrigerant is found which requires brazing, all of the refrigerant shall be recovered from the system, or isolated (by means of shut off valves) in a part of the system remote from the leak. Oxygen free nitrogen (OFN) shall then be purged through the system both before and during the brazing process.

12. Removal and evacuation

When breaking into the refrigerant circuit to make repairs or for any other purpose conventional procedures shall be used. However, it is important that best practice is followed since flammability is a consideration. The following procedure shall be adhered to:

Remove refrigerant;

Purge the circuit with inert gas;

Evacuate;

Purge again with inert gas;

Open the circuit by cutting or brazing.

The refrigerant charge shall be recovered into the correct recovery cylinders. The system shall be flushed with OFN to render the unit safe. This process may need to be repeated several times. Compressed air or oxygen shall not be used for this task.

Flushing shall be achieved by breaking the vacuum in the system with OFN and continuing to fill until the working pressure is achieved, then venting to atmosphere, and finally pulling down to a vacuum. This process shall be repeated until no refrigerant is within the system. When the final OFN charge is used, the system shall be vented down to atmospheric pressure to enable work to take place. This operation is absolutely vital if brazing operations on the pipe-work are to take place.

Ensure that the outlet for the vacuum pump is not close to any ignition sources and there is ventilation available.

13. Charging procedures

In addition to conventional charging procedures, the following requirements shall be followed.

Ensure that contamination of different refrigerants does not occur when using charging equipment. Hoses or lines shall be as short as possible to minimise the amount of refrigerant contained in them.

Cylinders shall be kept upright.

Ensure that the refrigeration system is earthed prior to charging the system with refrigerant.

Label the system when charging is complete (if not already).

Extreme care shall be taken not to overfill the refrigeration system. Prior to recharging the system it shall be pressure tested with OFN. The system shall be leak tested on completion of charging but prior to commissioning. A follow up leak test shall be carried out prior to leaving the site.

14. Decommissioning

Before carrying out this procedure, it is essential that the technician is completely familiar with the equipment and all its detail. It is recommended good practice that all refrigerants are recovered safely. Prior to the task being carried out, an oil and refrigerant sample shall be taken in case analysis is required prior to re-use of reclaimed refrigerant. It is essential that electrical power is available before the task is commenced.

a) Become familiar with the equipment and its operation.

b) Isolate system electrically.

c) Before attempting the procedure ensure that: Mechanical handling equipment is available, if required, for handling refrigerant cylinders;

All personal protective equipment is available and being used correctly; The recovery process is

Refrigerant R32

■ Warnings (use of refrigerant R32)

- supervised at all times by a competent person;
Recovery equipment and cylinders conform to the appropriate standards.
- d) Pump down refrigerant system, if possible.
 - e) If a vacuum is not possible, make a manifold so that refrigerant can be removed from various parts of the system.
 - f) Make sure that cylinder is situated on the scales before recovery takes place.
 - g) Start the recovery machine and operate in accordance with manufacturer's instructions.
 - h) Do not overfill cylinders. (No more than 80 % volume liquid charge).
 - i) Do not exceed the maximum working pressure of the cylinder, even temporarily.
 - j) When the cylinders have been filled correctly and the process completed, make sure that the cylinders and the equipment are removed from site promptly and all isolation valves on the equipment are closed off.
 - k) Recovered refrigerant shall not be charged into another refrigeration system unless it has been cleaned and checked.

15. Labelling

Equipment shall be labelled stating that it has been de-commissioned and emptied of refrigerant. The label shall be dated and signed. Ensure that there are labels on the equipment stating the equipment contains flammable refrigerant.

16. Recovery

When removing refrigerant from a system, either for servicing or decommissioning, it is recommended good practice that all refrigerants are removed safely.

When transferring refrigerant into cylinders, ensure that only appropriate refrigerant recovery cylinders are employed.

Ensure that the correct number of cylinders for holding the total system charge is available. All cylinders to be used are designated for the recovered refrigerant and labelled for that refrigerant (i.e. special cylinders for the recovery of refrigerant). Cylinders shall be complete with pressure relief valve and associated shut-off valves in good working order. Empty recovery cylinders are evacuated and, if possible, cooled before recovery occurs.

The recovery equipment shall be in good working order with a set of instructions concerning the equipment that is at hand and shall be suitable for the recovery of flammable refrigerants. In addition, a set of calibrated weighing scales shall be available and in good working order. Hoses shall be complete with leak-free disconnect couplings and in good condition. Before using the recovery machine, check that it is in satisfactory working order, has been properly maintained and that any associated electrical components are sealed to prevent ignition in the event of a refrigerant release. Consult manufacturer if in doubt.

The recovered refrigerant shall be returned to the refrigerant supplier in the correct recovery cylinder, and the relevant Waste Transfer Note arranged. Do not mix refrigerants in recovery units and especially not in cylinders. If compressors or compressor oils are to be removed, ensure that they have been evacuated to an acceptable level to make certain that flammable refrigerant does not remain within the lubricant. The evacuation process shall be carried out prior to returning the compressor to the suppliers. Only electric heating to the compressor body shall be employed to accelerate this process. When oil is drained from a system, it shall be carried out safely.





Note About Fluorinated Gasses

-Fluorinated greenhouse gases are contained in hermetically sealed equipment. For specific information on the type, the amount and the CO₂ equivalent in tonnes of the fluorinated greenhouse gas (on some models), please refer to the relevant label on the unit itself.

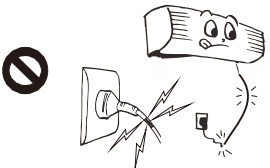
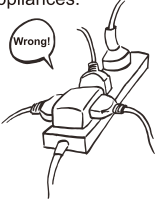
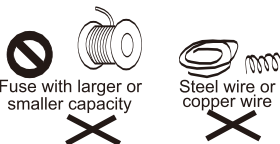
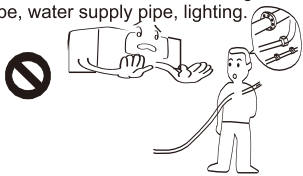
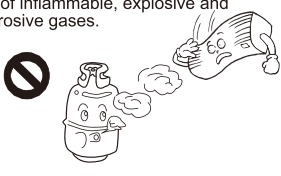

-Installation, service, maintenance and repair of this unit must be performed by a certified technician.

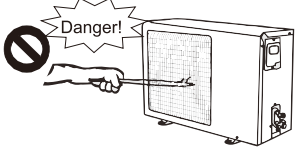

-Product uninstallation and recycling must be performed by a certified technician.

Safety Precautions

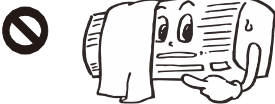
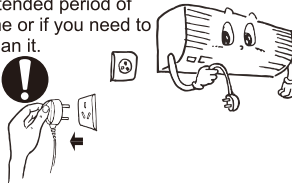
<p>Never use broken or unspecified power cable, power plug and socket.</p>  <p>Otherwise it will lead to fire disaster, electric shock or short circuit.</p>	<p>Never use the same power socket with other electrical appliances.</p>  <p>Otherwise it will lead to fire disaster, electric shock or short circuit.</p>	<p>Never use fuse with improper capacity or other metal fuses</p>  <p>Otherwise it will lead to fire disaster, electric shock or short circuit.</p>
<p>The air conditioner must be well grounded and the grounding wire should not be connected to the gas pipe, water supply pipe, lighting.</p>  <p>Otherwise it will lead to accidents.</p>	<p>Never put air conditioner in the place where the combustible gas may be leaked. Never use it in the environment full of inflammable, explosive and corrosive gases.</p>  <p>Otherwise it will lead to fire disaster or explosions.</p>	<p>Never put chemical spray or paint near the air conditioner or spray towards the air conditioner.</p>  <p>Otherwise it will lead to fire disaster or explosions.</p>
<p>Never wash air conditioner with water or other fluid, as the water may penetrate into the panel.</p>  <p>Otherwise, the internal electrical parts may be damaged.</p>	<p>When the fan blade is running, do not touch the air outlet of the indoor unit and outdoor unit. Also, do not put your hand or any other objects into the grills.</p>  <p>Otherwise it will cause injury to the user or damage to the air conditioner.</p>	<p>Never let the air conditioner blow towards heater appliances.</p>  <p>Otherwise it will lead to incomplete combustion and gas poisoning.</p>
<p>Do not repair the air conditioner without proper supervision Please contact our service center so a professional personnel can assist you.</p> <p>Ensure the place of installation can support the weight of the air conditioner. If the installation bracket for the outdoor unit is broken, do not place the air conditioner on it as it may cause injury or it may damage the air conditioner.</p> <p>Do not stand on the outdoor unit or put objects on it. It may cause injury or it may damage the air conditioner.</p> <p>Do not plug or unplug the power plugs with wet hands and do not operate the remote control with wet hands. Otherwise, it will damage the air conditioner or it will lead to electric shock.</p> <p>! If there anything strange occurs, such as a burning smell coming from the unit, stop the air conditioner immediately and cut off the power supply. If measures are not taken in time, the air conditioner will be damaged. It may also lead to electric shock or fire disaster. Please contact our service center.</p> <p>! Make sure the power plug is completely inserted into the socket. Otherwise, it will lead to a fire disaster.</p> <p>! Regularly clean the dust from the power plug. Regularly cleaning can help avoid fire disasters.</p>		

Safety Precautions

<p>Do not block the air inlet and outlet of indoor unit and outdoor unit</p>  <p>Otherwise, it will influence the condition of the air conditioner.</p>	<p>For safety reason, unplug the power cord from the wall outlet if the air conditioner will not be used for an extended period of time or if you need to clean it.</p>  <p>Otherwise, it may cause injury,</p>	<p>Do not expose your body to the air flow for a long time. It is not good for your health.</p>  <p>Or it will do harm to your health.</p>
---	--	--

	<p>Do not directly blow at children, animals and plants Direct the airflow of the air conditioner so that it does not blow directly on children, animals and plants.</p>
	<p>Do not put the objects, which need to avoid moisture, under the indoor unit and outdoor unit. Sometimes the moisture in the air will be condensed as water-drop, thus damaging the objects which need to avoid moisture.</p>
	<p>Do not touch the aluminum parts of indoor unit or outdoor unit of air conditioner. The sharp aluminum sheet may cause injury.</p>
	<p>Proper Ventilation Insufficient ventilation will cause oxygen deficiency and headaches. If the air conditioner is used simultaneously with any gas burning appliance, please remember to ensure proper ventilation.</p> <p>When the air conditioner is cooling your home, keep sun light away. Otherwise it will influence the refrigeration effect.</p>

 Temperature Conditions									
<p>In the following temperature range, the air conditioning protective equipment will run and the air conditioner will stop. As a result, to ensure the normal operation of air conditioner, the following conditions should be avoided.</p>									
<table border="1" style="width: 100%;"> <tr> <td style="width: 15%;">Cooling</td> <td style="width: 35%;">Outdoor temperature</td> <td style="width: 15%;">21-43°C</td> <td style="width: 35%;"></td> </tr> <tr> <td></td> <td>Room temperature</td> <td>21-32°C</td> <td></td> </tr> </table>	Cooling	Outdoor temperature	21-43°C			Room temperature	21-32°C		
Cooling	Outdoor temperature	21-43°C							
	Room temperature	21-32°C							
<p>If the power is not cut off, and the machine is started immediately after stoppage or the mode is changed during operation, the protective device in the unit will work. The air conditioner's compressor stop operating for 3 minutes to protect the compressor. After 3 minutes, the compressor will start running.</p>									

 Inspection before operation	
<p>Newly installed air conditioner</p>	<p>1. Check if the installation is reasonable; 2. Check if the batteries are installed in the remote controller; 3. Check if the power supply is connected.</p>

Name and Function of each Part

Indoor Unit

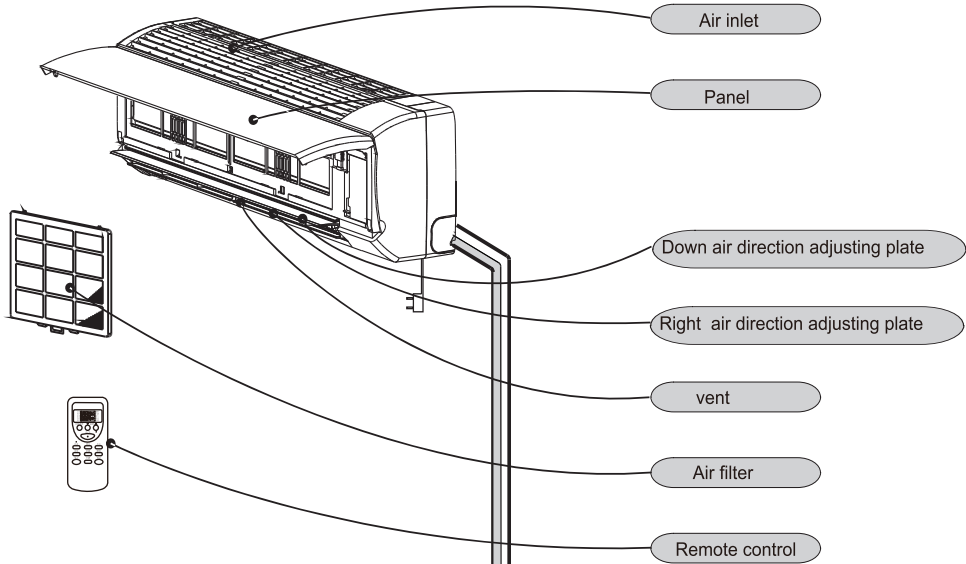

Outdoor Unit

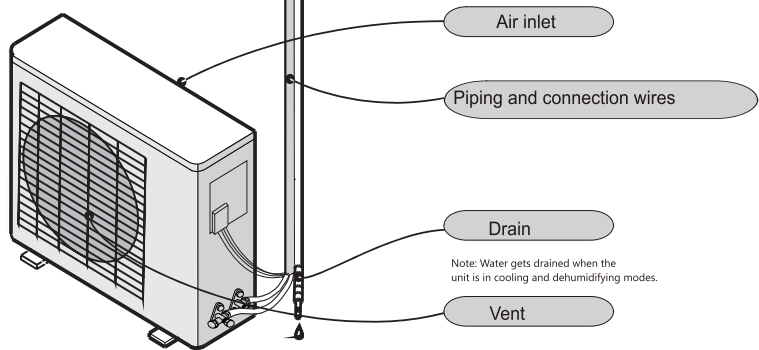

Note: Water gets drained when the unit is in cooling and dehumidifying modes.

*Images may differ in appearance from the actual product.

Display icons

Running indicator:  

Timer indicator:  

Sleeping indicator:  

Cooling indicator: 

Heating indicator: 

Dehumidifying indicator: 

Ventilation run icon: 

Auto indication icon: 

Low wind run icon: 

Stroke run icon: 

The high wind run icon: 

Strong run icon: 

Digital display tube icon: 

Electric heating run icon:  

Above figure shows all indications for the purpose of the explanation but practically only the pertinent parts are indicated.

The indicator may be changed, but it does not affect your operation.

Note: You can check product parameters from the nameplate.

Use of remote controller

- On first use, insert battery and ensure the Plus-n-Minus is in correct connection.
- Ensure that remote controller is pointed at the signal receiver without any obstruction; Do not make the remote controller fall off or throw it carelessly; Any liquid cannot flow into the remote controller; Do not put the remote controller near the high temperature objects or on the place exposed to direct sunlight or strong light.
- If the remote controller is unable to be operated, please reinsert the batteries after removing it for 30 second. If it is still unable to be operated, please replace new batteries. The useless batteries should be disposed as relevant national regulations.
- Do not mix use of new-and-used batteries or different type batteries, otherwise, the remote controller should be unable to be operated.
- If the remote controller is not used for a long time, please take out the batteries to prevent the remote controller from being damaged by the leaked fluid.
- Please understand that this type of remote controller is general type, including the entire function button. The specific function is subject to the function of A/C.

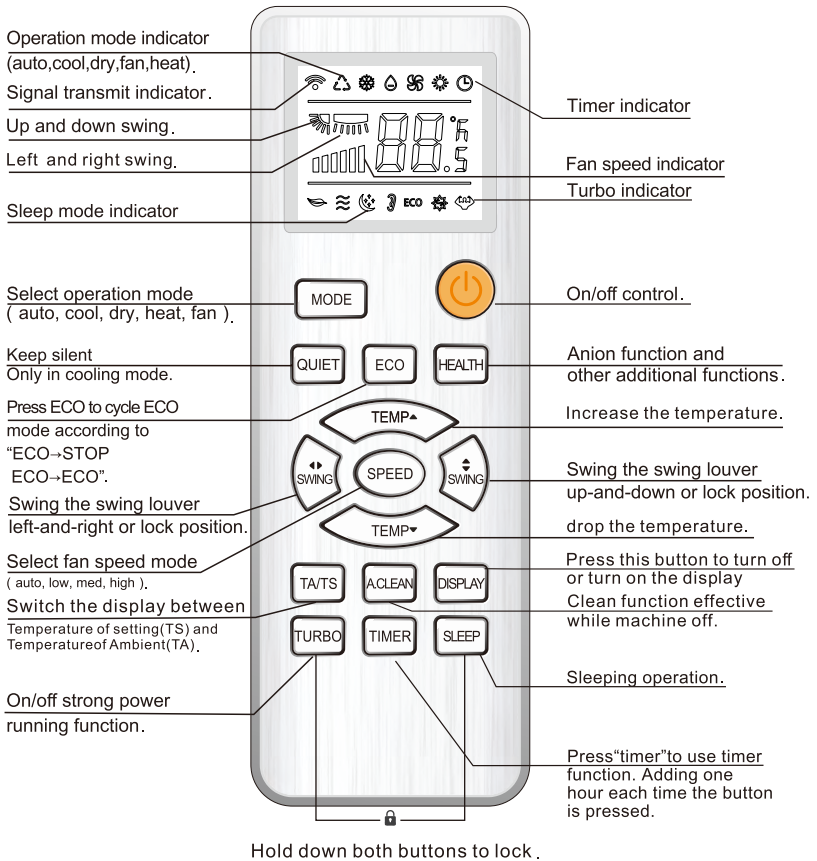

★ The picture of the remote control is for reference only, please refer to the actual product.

PS: cooling only A/C cannot operate heating function. No corresponding action when the remote controller is pressed "heating" button or set mode to heating. Please do not set mode to heating.

Use of remote controller

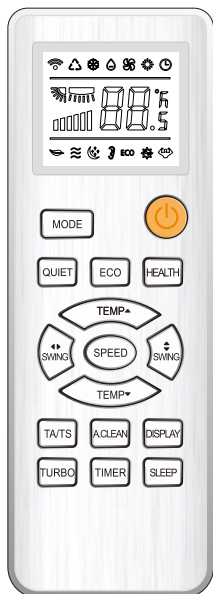

On/Off Button

* On/Off control, for the air conditioning turned on or off.

Mode Button

* Cycle mode when this button is pressed as follows:

AUTO→COOL→DRY→HEAT→FAN→AUTO

Note: Under "CLEAN" and "FAN" mode, cannot set temperature.

△/▽ (Temperature/Time) Button

* △/▽ (temp/timer) control button, each time press "△" to set temperature rises 1 °C, press "▽" to set temperature drops 1 .

* Temperature setting range is 16~32 °C.

PS: The button is invalid when in clean and fan mode. Button "TIMER" should be operated with "time". Specific operation is subject to button timer description.

ECO Button

* Pressing ECO to switch cyclically according to "ECO→STOP ECO→ECO".

Guide Louver Button

* Flap guide louver up-and-down when this button is pressed. Re-press to fix louver.

Swing Louver Button

* Button swing louver (internal louver): swing "swing louver" left-and-right or fix louver.



(only available for the A/C with this function)

Fan Speed Button

* Cycle fan speed when this button is pressed, as follow:

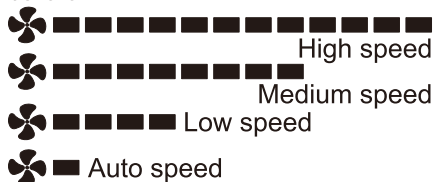

Turbo Button

* Remote controller enters un-strong run mode by default. TURBO is invalid under "AUTO", "DRY", mode (no TURBO indication and signal). Cycle TURBO on/off when this button is pressed under other modes. Fan speed should not indicate when TURBO is operating. Cancel TURBO after changing mode when TURBO is operating. Cancel TURBO when A/C enters sleep mode.

Use of remote controller

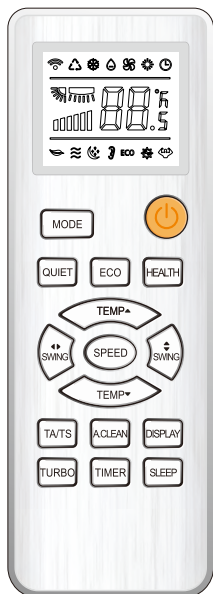

Lock Button

* Press the TURBO and SLEEP keys at the same time to lock all the functions of the remote control, Press again to unlock.

TATS Button (only available for the A/C with this function)

* Press the indoor machine once to display TS value (TS: setting temperature value), press again to display the indoor temperature TA value (current indoor environment temperature), and switch the cycle. This function is optional, the electronic control panel does not support this function by default.

Clean Button

* Only under remoter controller condition of power off, can it transmit "auto clean" signal when this button is pressed to power on.

* A/C enters mode cool, temperature 25°C, high speed when the button is pressed to power on under remote controller condition of power off. Auto clean arrow icon should disappear automatically after 6 minutes when it indicates. Any switching of mode should make auto clean arrow icon disappear.

Health Button (only available for the A/C with this function)

* Only by adding related auxiliary components (such as UV lamp and anion generator) can it be realized. This feature is optional and is not available by default.

Sleep Button

* A/C enters low speed mode by default under sleep mode. Fan speed is adjustable.

Timer Button

* Set timer power off under A/C condition of power on. Set timer power on under A/C condition of power off.

* Timing time ranges from 1h to 24h.

* Timing setting should exit after 5s if the button is failed to press, but the timer will be valid.

* Timing off: When powered on, press the timer button timing off, the default timing is one hour, other times are the previous timing value. Continuous time will increase by one hour between 1-24, then press again at 24 clock to exit the time.

* Press the mode key and temperature plus/minus key will exit the timing display and the timing is valid.

Cleaning and Maintenance

[Cleaning and Maintenance]

The power must be shut off before maintenance.

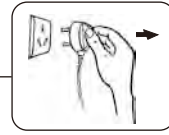

1. Remove the filter screen

Make sure the air conditioner is turned off.

Gently push up the panel and remove it by lifting up the filter screen towards yourself.



2. Clean the filter screen

Gently pat it or clean with vacuum cleaner. If the filter screen is too dirty, it can be washed by the solution containing small amount of neutral detergent (example: dishwashing liquid). After washing, dry the filter screen and install it to the original location.

Note: The filter screen should not be exposed to sunlight, dried by stove fire, or washed with hot water above 40°C.



3. Clean the air conditioner

For safety purpose, the power plug must be unplugged before cleaning to avoid electric shock.

Do not wash the air conditioner with water

Wipe the machine with soft cloth.

Do not wash the machine with volatile oil, gasoline, diluent, putty powder, etc.

For fingerprint or oil contamination, please wash with household neutral detergent.

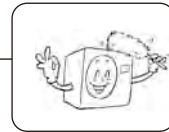

4. If air conditioner has not been used in a long time.

Before:

Shut down the air conditioner and pull out the power plug.

Please carefully clean and maintain the air filter screen and other parts.

Cover the outdoor unit with plastic cloth to prevent dust or waste from entering into the machine.

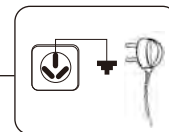

After:

Check if the air inlet and air outlet of indoor unit and outdoor unit are blocked.

The protective cover of outdoor unit must be removed.

Check if the installation base is corrosive or rusted.

Check if the power cable and

grounding wire are in normal condition.

Check if the drain hose is bent, end is lifted, or is blocked.

Before operation, check and make sure the air filter screen is well installed. If the machine is running without air filter

screen, the air conditioner may be damaged by dust and foreign substances.



Notices for Installation

[Notices for Installation]

Installation environment

The air conditioner must be installed by professionals. The "Installation Instructions" is only for the reference of professional installation personnel! The installation must conform to our after-sale service regulations.

1. Requirements for installation environment of indoor unit
 1. Install on the non-vibration and solid wall and make horizontal adjustment. Put the back of wall-hanging unit against the wall.
 2. There are no obstacles prevent the proper air circulation at air inlet and outlet.
 3. Keep away from the heat source and inflammables and places where the moisture is strong.
 4. The panel of the indoor unit should avoid being exposed to sunlight. The operation location should not have strong electromagnetic interference.
 5. It should be convenient for connecting the outdoor unit and draining through drain hose.
 6. It should be near to the power socket for dedicated line.
 7. Install by following the instructions on the diagram to ensure the distance between the unit and wall, ceiling, and other obstacles, so as to ensure the normal operation and maintenance of unit.
 8. Height of the indoor unit to the floor should be higher than the sight level.
2. Requirements for installation environment of outdoor unit
 1. Installation foundation should be solid and firm.
 2. Install by following the instructions in the diagram to ensure the distance between the unit and other obstacles.
 3. It should add weather-proof and sunshade shelter to prevent the outdoor unit from being damaged by rain and sunlight. Be careful not to influence the heat dissipation.
 4. Keep away from the heat source and inflammables.
 5. It should install in a proper place to prevent the operation noise and circulated gas of outdoor unit from influencing the neighbors.

Notices for Installation

1. The fuse types for the series of indoor unit include 50T or 50F and the rated parameter is T 3.15A 250V. No fuse is equipped on the machine. Please select proper fuses or other over-current protective equipment for power supply in accordance with the requirements on the main nameplate.
2. The series of air conditioners can be safely used under the external static pressure of 0.8-1.05 times of standard atmospheric pressure.
3. The air conditioner should be installed in accordance with national wiring rules.
4. Please check if the electric circuit connection, electric wires, electric meter, fuses, sockets, and switches for air conditioners conform to the national electrical safety standards. Make sure there is good grounding protection. Grounding wire must not be connected to the water supply pipe, gas pipe and other unreliable places. (Note: Installation and connection of electrical equipment should be performed by qualified professional technical personnel holding electrician certificate so as to avoid accidents)
5. Please check if the power supply for air conditioner conforms to the requirements of national standards.

	<p>When installing or handling the air conditioner, no other gases except for specified refrigerant is allowed to mix in the refrigerant pipeline system. Otherwise the refrigerating cycle will be in abnormal high pressure and lead to pipe breaking and even personal injury.</p>
	<p>The unused power lines should not be tied up with bandage. Keep the lines in the piping tank in the back of the indoor unit. Otherwise it may cause heating and even fire.</p>
	<p>Do not process or prolong the power lines and use multiple distribution wires Otherwise it may cause problems like poor contact, poor insulation and exceeding the permissible current, which may lead to dangerous situations like electric shock, fire, etc.</p>
	<p>The connecting terminals for indoor and outdoor units must be firmly connected and fixed with fixed device. Otherwise the terminal connecting position will be heated and cause fire.</p>
	<p>The air conditioner must use independent circuit and must be equipped with delay action circuit breaker or auto-circuit breaker. If the air conditioner use shared line with other devices, it may be heated and cause fire.</p>
	<p>After installation, check to make sure no refrigerant is leaked, refrigerant system is well sealed and drain hose is unobstructed. Otherwise the refrigerating effect will be influenced and the refrigerant leakage will do harm to human's health.</p>

Installation instructions

[Installation Guidance]

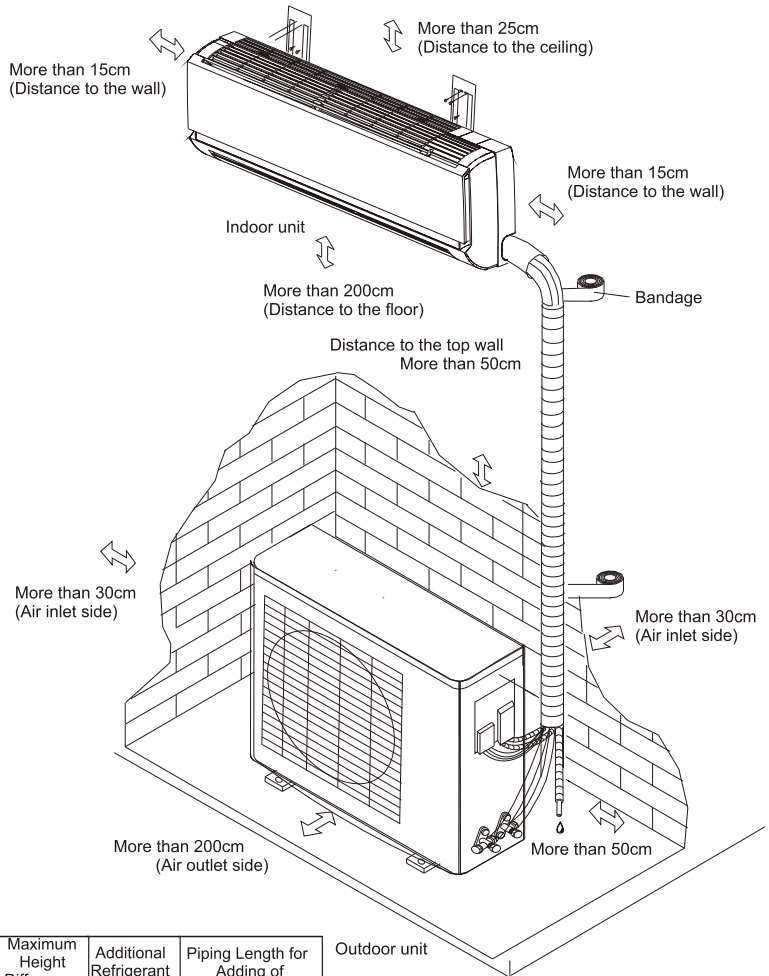

Cooling Capacity	Maximum Piping Length(m)	Maximum Height Difference (m)	Additional Refrigerant (g/m)	Piping Length for Adding of Refrigerant(m)
1.0/1.5 HP	10	5	20	4
2.0/2.5 HP	10	8	30	4

Recommended cable specification				
Cooling Capacity	Suggested that type	1.0 HP	1.5/2.0 HP	2.5 HP
Indoor power cord	H05VV-F	≥1.0mm ²	≥1.5mm ²	≥2.5mm ²
Indoor and outdoor power cord	H07RN	≥1.0mm ²	≥1.5mm ²	≥2.5mm ²
Indoor and outdoor signal line	H05RN	≥0.75mm ²	≥0.75mm ²	≥0.75mm ²

⚠ This is the schematic diagram and not the actual product.

Warning

- When the drainage nozzle is in the right of the indoor unit, as shown above, the left side of the indoor unit should not be 10mm lower and 20mm higher than the right side, so as to ensure the smooth draining of condensed water.
- When the drainage nozzle is in the left of the indoor unit, the right side of the indoor unit should not be 10mm lower or 20mm higher than the left side, so as to ensure the smooth draining of condensed water.

Installation instructions

[Installation Guidance]

Installation of Indoor unit

● Mount the wall-hung plate and locate the wall-through hole.

- Find proper location and adjust the mounting plate horizontally with level meter.
- By considering the actual situation, the wall-through hole should be made outer part downward a little than the inner part. Insert the wall-through sleeve and put on the cover.
- Wall-hung plate should be fixed with at least 5 screws. The screws should be distributed evenly.

Note:

The number of cables of different air conditioning models will be different, please refer to the electrical diagram for wiring according to the actual number.

Steps:

Open the panel, remove the cover plate, and connect the cable correctly as shown in the electrical diagram.

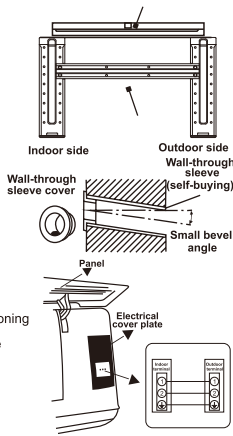

Piping Connection

● Joint Connection

- Align with the center of pipe, fasten the screws wit hand.
- Screw the nuts with torque spanner and wrench. Screw according to the instructions of torque spanner. The torque should not be too large or too small.

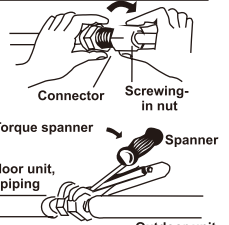

Diameter of connecting pipe(mm)	Tightening torque of nut (N·m)
6 or 6.35	15-20
9.52	31-35
12 or 12.7	45-50
15.88 or 16	60-65

Outdoor unit Piping

- Wrap the connector with lagging cover

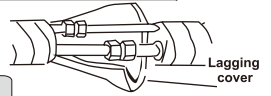

Operation Method for Exhausting Air

● Method for exhausting air

- Remove the nuts on the two-way valve and three-way valve.
- Turn the valve handle of two-way valve for 90 degree and keep for 10 seconds, and then close.
- Check the connecting part of pipe with soapy water to see if it leaks air. If no air leakage, open the two-way valve and then close.
- During exhausting air, press the pin on the service port of three-way valve with hex wrench for 3 seconds and then release for 1 minute. Open the two-way valve and then close. Repeat the above procedure for 3 times to exhaust air.
- Open the two-way valve and three-way valve with hex wrench. Screw in the nuts and finish the operation of exhausting air.

90 degree (one quarter turn)

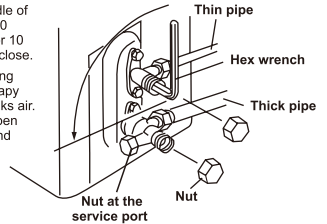

● Arrange pipeline and install the indoor unit

- Arrange the connecting pipe, drainage pipe and electric wire at bottom to facilitate drainage. Electric wire and indoor & outdoor connecting wire should not be entangled together.

Note:
Drain hose of indoor unit can only be drawn out from its own side.

- Fix the indoor unit on the wall-hung board.

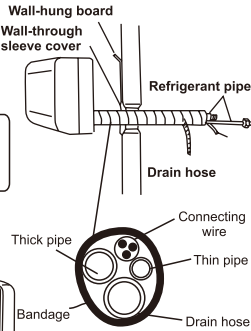
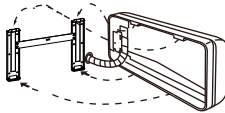

Installation of Outdoor Unit

● Installation and fixation

Fix the mounting bracket (to be purchased additionally) on the wall and fix the outdoor unit firmly on the mounting bracket and remain level.

● Connect the electric wire of outdoor unit

- Loosen the screws of large handle of outdoor unit.
- Connect the connecting lines of indoor and outdoor units according to the connecting diagram for the large handle.

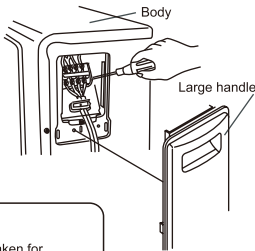

Warning

The complete measures must be taken for grounding connection. When the electric wire is suffering the external force, it should ensure the core wires (yellow/green lines) of grounding wire to be stretched after other current-conductor core wires.

● Vacuum method (must be used for R410A refrigerant)

- Remove the nut on the two-way valve and nut on service port. Connect the low-pressure hose on the dedicated pressure gage to the service port. (The shut-off valve on two-way and three-way valve are in off status)
- Fully open the low-pressure switch on the pressure gage and start vacuum pump.
- Vacuumize for at least 25 minutes and make sure the pressure gage indication is -0.1MPa. Close the low-pressure switch and then close vacuum pump. If the pressure does not increase within 5 minutes, please perform the next operation. Otherwise you should vacuumize again.
- After vacuumizing, counterclockwise open the shut-off valve on the two-way valve and keep 10 seconds and then stop. Check the leakage (If any leakage is found, reconnect the pipe and then perform the above procedure again).
- Quickly remove the low-pressure hose and open two-way valve and three-valve with hex wrench.
- Fasten the nut on the valve body.

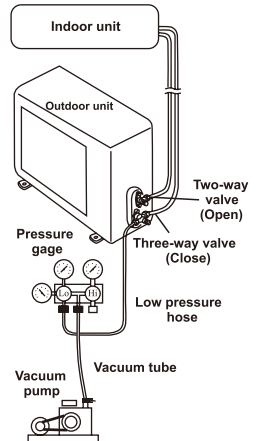

Installation instructions

[Installation Guidance]

Inspection after installation

Inspection Items	Problems caused by improper installation
Check if installation is firm	Unit may have been dropped, vibrated or made a sound.
Check if there is any leakage	It may cause insufficiency of cooling (heating) capacity.
Check if the heat insulation of machine is sufficient	Condensation may occur.
Check if the drainage is smooth	Condensation may occur.
Check if the power voltage conforms to that on the product nameplate	The unit may not work properly.
Check if the lines and pipes are properly installed.	The unit may not work properly.
Check if the machine is safely grounded.	There might be a leakage.
Check if the electric wire type conforms to the specification.	The unit may not work properly.
The air outlet and inlet of indoor and outdoor unit are obstructed.	It may cause insufficiency of cooling (heating) capacity

Pilot run

● Preparation for test run

1. Power should not be turned on before completion of all installation works.
2. All lines are properly connected and all the electric wires are firmly connected.
3. Open the shut-off valve of thick and thin pipes
4. All the unnecessary materials, especially metal wire and thread, should be removed from the machine.

● Method for test run

1. Turn on the power, press ON/OFF button on the remote control to start the air conditioner.
2. Press the Mode Button to check each type of mode's operate normally.

Fault analysis

[Fault Analysis]

The following examples are not faults.

After shutting down, the air conditioner cannot restart immediately.	If the user restarts the air conditioner when it is just stopped, the 3-minute protective timer of air conditioner will be automatically activated and the air conditioner will be restarted 3 minutes later.
If the air conditioner is shut down when it is in refrigerating mode, the wind supply should not be turned off immediately and wind deflector should not be closed immediately. (for machine type marked with *)	It is because that the air conditioner is executing the mould-proof operation and the indoor unit is running with low wind and wind deflector will be closed after 30 seconds.
No wind is supplied in the beginning of heating	Before the heat exchanger of indoor unit is warm, stop wind supply to avoid blowing cold wind (for 2 to 5 minutes).
There is strange smell coming out when start-up.	It is because that the smoke and smell from cosmetics, wall or furniture is attached on the air conditioner and is dissipated by wind blowing.
Water flow sound can be heard during operation of the air conditioner	It is the flowing sound of internal refrigerant of the air conditioner
Crackle can be heard after starting or stopping the heating or refrigerating	It is caused by the thermal expansion and extraction.

Before contacting the service personnel, please check the following table that might be of help to you.

"Malfunction"	Analysis on the "Malfunction"
Air conditioner is unable to run.	<ol style="list-style-type: none"> ① Check if power is failed. ② Check if power is connected. ③ Check if Timing ON/OFF function is set. ④ Check if the voltage is too high or too low. ⑤ Check if the residual current circuit breaker is switched off.
Cooling (heating) effect is not good.	<ol style="list-style-type: none"> ① Check if the set temperature is OK. ② Check if the air inlet and outlet of indoor and outdoor unit are blocked. ③ Check if the air filter screen is blocked by too much dirt. ④ Check if all the doors and windows are closed. ⑤ Check if there are any heat sources.
Remote control is not functional	<ol style="list-style-type: none"> ① When the remote control is exposed to direct sunlight or strong light, the remote signal may not be received. In this case, please block out the sunlight or dim the lighting. ② Check if it is within the reception range and if any obstacles. ③ Check if the battery voltage is sufficient. Or you should replace with new batteries. ④ If the remote control display is not clear, please replace with new batteries.

In case of following situations, please stop operation immediately, shut off power, and contact our dealers or authorized service center.

- The fuse always burn out and electric switch is always disconnected.
- Electric wire is abnormally heated or the wire insulation is broken.
- Other abnormal status.

